

INOXMARE®

PANHEAD CHIPBOARD SCREWS TX, FULL THREAD



DATASHEET
ITEM 9112

FASTENERS | MARINE HARDWARE | FITTINGS | SOLAR

ITEM 9112

TECHNICAL SPECIFICATIONS

Panhead chipboard screws with TX drive are mainly used in general timber construction for various types of timber constructions. The Panhead serves a purely decorative purpose. Full-thread screws are particularly

suitable for fastening fittings and hinges. In order to prevent splicing and splintering, we recommend pre-drilling accordingly.

Material	stainless steel
Quality	A2
Thread type	wood thread
Surface	clean and bright
Hexalobular internal drive	ISO 10664

YOUR ADVANTAGES



TX-DRIVE = FASTER SCREWING

- › Improved torque transmission
- › Optimal centering
- › Minimises drive and bit wear



UNIVERSALLY APPLICABLE

PRACTICES



WOOD AND FURNITURE CONSTRUCTIONS

FASTENERS | MARINE HARDWARE | FITTINGS | SOLAR

DIMENSIONS (MM)

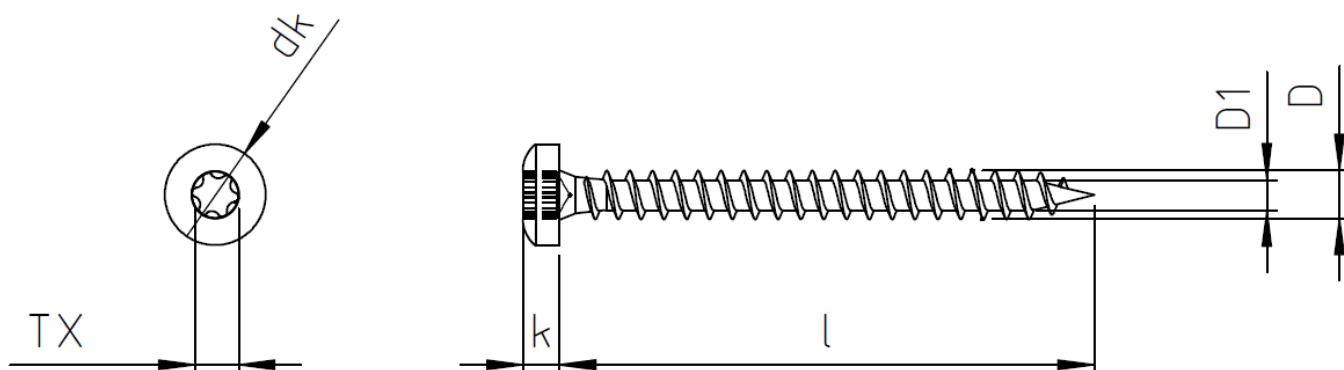

Diameter D	3	3,5	4	4,5	5	6
k	2,10 – 2,50	2,20 – 2,60	2,60 – 3,00	2,70 – 3,10	3,30 – 3,70	4,00 – 4,40
dk	5,60 – 6,00	6,42 – 7,00	7,42 – 8,00	8,42 – 9,00	9,42 – 10,00	11,30 – 12,00
D ₁	1,80 – 2,00	2,00 – 2,20	2,30 – 2,50	2,50 – 2,70	2,80 – 3,10	3,50 – 3,80
Ø 	2	2	2	2	3	3
TX	TX 10	TX 10	TX 20	TX 20	TX 25	TX 25

FASTENERS | MARINE HARDWARE | FITTINGS | SOLAR

DIMENSIONS (MM)

Length l / Ø	3	3,5	4	4,5	5	6
10 ± 0,7	X					
12 ± 0,7	X	X	X			
13 ± 0,7	X	X	X			
16 ± 0,7	X	X	X	X		
20 ± 0,7	X	X	X	X	X	X
25 ± 1,0	X	X	X	X	X	X
30 ± 1,0	X	X	X	X	X	X
35 ± 1,0		X	X	X	X	X
40 ± 1,0		X	X	X	X	X
45 ± 1,0			X	X	X	X
50 ± 1,0			X	X	X	X
60 ± 1,2			X	X	X	X
70 ± 1,2			X	X	X	X
80 ± 1,2					X	X
90 ± 1,5					X	X
100 ± 1,5						
110 ± 1,5						
120 ± 1,5						
130 ± 1,7						

X = available ex stock

Further dimensions are available on request

FASTENERS | MARINE HARDWARE | FITTINGS | SOLAR

Via Pomposa, 51/i
47924 - Rimini (RN) - ITALY

Tel. +390541.794444 Fax +390541.794490
info@inoxmare.it -www.inoxmare.com